

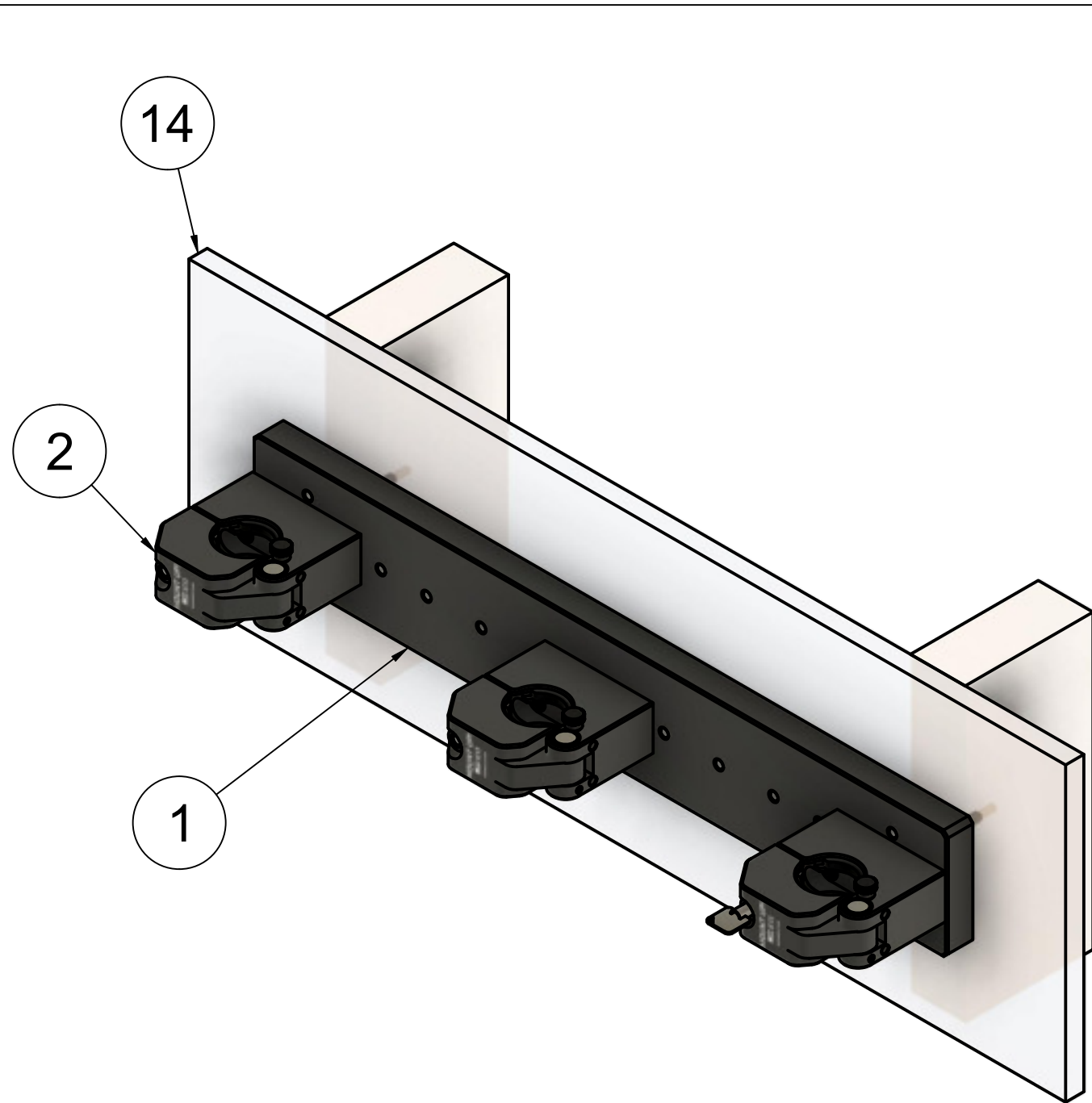

Installation Instructions

Mount Up! Three Gun Vertical Mount (500053)

1. Unpack the contents of your package and remove the red clevis pin retaining sticker on the right-hand side of your clamping bracket assembly (#2). Break your clamping bracket assembly down into three pieces for installation (front assembly, clevis pin, and rear block).
2. Locate the wood stud where you want to mount your bracket. Brackets can also be installed into block or concrete walls with appropriate anchors (not included).
3. Mark either the top or bottom hole location of the diamond-shaped mounting plate (#1) on the wall.
4. Drill a 3/16" pilot hole at this location, into the stud, **AT LEAST 2-1/2" DEEP into the stud.**
5. Screw the lag bolt (#4) with washer (#3) into the stud using a 7/16" socket and ratchet. Secure, but do not over-tighten.
6. Place your bubble level against one of the flat sides of the mounting plate (#1) and mark the location for the second hole.
7. Repeat steps 4 and 5 to mount the plate on the wall.
8. Cover the lag bolt heads with the black covers (#5).
9. Choose the four "bumpers" (#s 6, 10, 11) that you need for your firearm using the guide below. Press them into the grooves on the inside of the front and rear blocks of the clamping bracket assembly that you disassembled in step 1.
10. Using a 3/16" allen key or driver, mount the rear block to the mounting plate (#1) using the 1/4"-20 socket head cap screws (#13). The rear block can be oriented so that the release button on the left or right, depending on user preference. **THE TOP RAIL/OPTIC OF THE WEAPON SHOULD BE INSERTED INTO THE BRACKET ON THE SAME SIDE AS THE RED BUTTON.**
11. Align the holes in the rear block and the front block assembly and insert the clevis pin to join the parts. **THE HOLE IN THE CLEVIS PIN MUST BE ALIGNED WITH THE HOLE IN THE REAR BLOCK.**
12. Use a small hammer or mallet to pin the clevis pin in place, using the 1/8" spring pin (#7). Use a pin punch (if available) or the second included spring pin (#7) to tap the spring pin slightly past flush.
13. Screw the nylon thumb screw (#8) into place on the top of the rear block. The angle on your buffer tube will rest against this post, preventing any damage to your weapon or bracket while in use.
14. Screw the nylon tipped setscrew (#9) into the rear block on the side opposite of the red button, **ON THE BOTTOM** of the clamp assembly. **Some weapon systems may not hang perfectly vertical in the bracket depending on weight distribution. USE THIS SETSCREW TO ACHIEVE PERFECT VERTICAL ALIGNMENT.**
15. Unlock your bracket with the key. Open the bracket by depressing the red button and place your firearm into the bracket. Close the bracket and ensure that the red release button has engaged. The bracket clamps on the buffer tube between the castle nut, and the angled portion of the tube.
16. **TO LOCK YOUR BRACKET, REMOVE THE KEY (IF PRESENT), AND PRESS THE PLUNGER INTO THE LOCK. DOUBLE CHECK THAT THE PLUNGER REMAINS IN POSITION, AND CHECK FOR PROPER LOCK BY ATTEMPTING TO DEPRESS THE RED BUTTON.**



PARTS LIST			
ITEM	PART NUMBER	DESCRIPTION	QTY
1	500056	HORIZONTAL MOUNTING RAIL	1
2	500055	CLAMPING BRACKET ASSEMBLY	3
3	100071	1/4" WASHER	2
4	100070	1/4" LAG BOLT	2
5	100082	LAG BOLT COVER	2
6	100053	BUFFER TUBE BUMPER, MIL-SPEC	12
7	100074	1/8" SPRING PIN	3
8	100075	THUMB SCREW (BUFFER TUBE STOP)	3
9	100076	NYLON SET SCREW (BUFFER TUBE ADJUSTMENT)	3
12	100062	KEY SET	1
13	100072	1/4" ALLEN HEAD CAP SCREW	6
14	WALL WITH 16IN STUDS	SUPPLIED BY YOU	1

WARNING: NEVER USE THIS DEVICE WITH A WEAPON THAT HAS A LOADED CHAMBER OR LOADED MAGAZINE INSERTED. ALWAYS VISUALLY INSPECT FOR CLEAR CHAMBER PRIOR TO USING THE DEVICE.

For installation instructions visit <https://ic13.us/productsupport/>



PROPRIETARY AND CONFIDENTIAL

THE INFORMATION CONTAINED IN THIS DRAWING IS THE SOLE PROPERTY OF IC13. ANY REPRODUCTION IN PART OR AS A WHOLE WITHOUT THE WRITTEN PERMISSION OF IC13 IS STRICTLY PROHIBITED.

UNLESS OTHERWISE SPECIFIED

DIMENSIONS ARE IN INCHES / TOLERANCES:
 ANGULAR: +/- 0.5 Deg
 FRACTIONAL: +/- .015"
 TWO PLACE DECIMAL: +/- .010"
 THREE PLACE DECIMAL: +/- .005"
 SEE 3D MODEL FOR DIMENSIONS NOT OTHERWISE SPECIFIED

DO NOT SCALE

DRAWN BY: Josh Sprecher
 DATE: 11/15/2021
 SCALE: 1:8
 SIZE: B
 SHEET: 1/2

STOCK AND FINISH

LENGTH:
 WIDTH:
 HEIGHT:
 FINISH:
 NOTES:

PART NUMBER

500053

REVISION

DESCRIPTION

Mount Up! Three Gun Vertical Overview

PARTS LIST			
ITEM	PART NAME	DESCRIPTION	QTY
1	500056 V60	HORIZONTAL MOUNTING RAIL	1
2	500055 V10	CLAMPING BRACKET ASSEMBLY	3
2.1	100050 V33	REAR BLOCK, BUFFER TUBE CLAMP	1
2.2	100073 V3	CLEVIS PIN, 3/8"	1
2.4	100051 V40	FRONT BLOCK, BUFFER TUBE CLAMP	1
2.5	100052-01 V36	BUTTON, BUFFER TUBE CLAMP	1
3	100071 V3	1/4" WASHER	2
4	100070 V7	1/4" LAG BOLT	2
5	100082 V3	LAG BOLT COVER	2
6	100053 V3	BUFFER TUBE BUMPER, MIL-SPEC	12
7	100074 V3	1/8" SPRING PIN	4
8	100075 V3	THUMB SCREW (BUFFER TUBE STOP)	3
9	100076 V2	NYLON SET SCREW (BUFFER TUBE ADJUSTMENT)	3
10	100054 V5	BUFFER TUBE BUMPER, COMMERCIAL (NOT SHOWN)	12
11	100055 V3	BUFFER TUBE BUMPER, PISTOL (NOT SHOWN)	12
12	100062 V3	KEY SET	1
13	100072 V3	1/4" ALLEN HEAD CAP SCREW	6
14	WALL WITH 16IN STUDS V4	SUPPLIED BY YOU	1

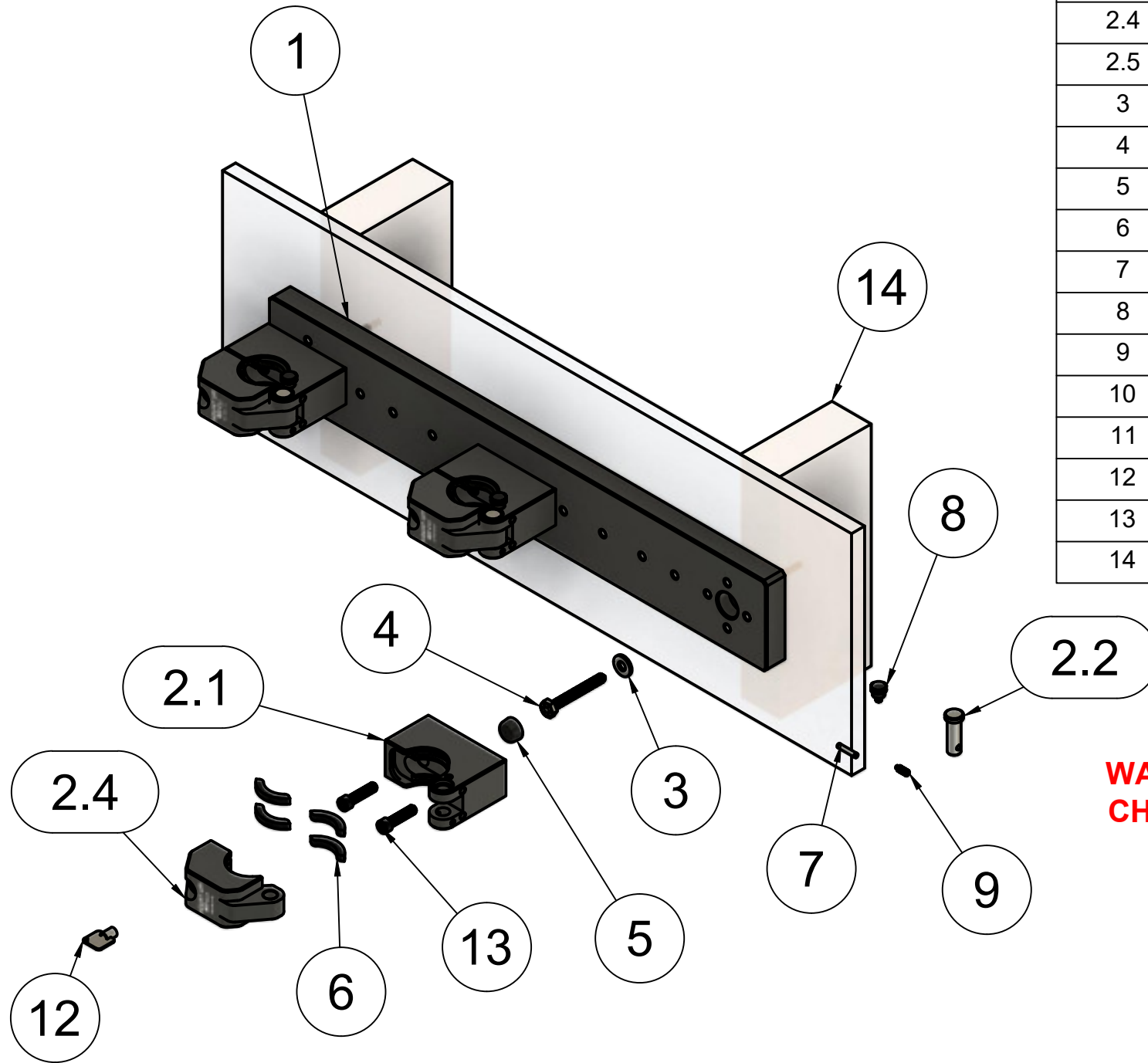

WARNING: NEVER USE THIS DEVICE WITH A WEAPON THAT HAS A LOADED CHAMBER OR LOADED MAGAZINE INSERTED. ALWAYS VISUALLY INSPECT FOR CLEAR CHAMBER PRIOR TO USING THE DEVICE.

For installation instructions visit <https://ic13.us/productsupport/>



PROPRIETARY AND CONFIDENTIAL

THE INFORMATION CONTAINED IN THIS DRAWING IS THE SOLE PROPERTY OF IC13. ANY REPRODUCTION IN PART OR AS A WHOLE WITHOUT THE WRITTEN PERMISSION OF IC13 IS STRICTLY PROHIBITED.

UNLESS OTHERWISE SPECIFIED

DIMENSIONS ARE IN INCHES / TOLERANCES:
 ANGULAR: +/- 0.5 Deg
 FRACTIONAL: +/- .015"
 TWO PLACE DECIMAL: +/- .010"
 THREE PLACE DECIMAL: +/- .005"
 SEE 3D MODEL FOR DIMENSIONS NOT OTHERWISE SPECIFIED

DO NOT SCALE

DRAWN BY: Josh Sprecher
 DATE: 11/15/2021
 SCALE: 1:4
 SIZE: B
 SHEET: 2/2

STOCK AND FINISH

LENGTH:
 WIDTH:
 HEIGHT:
 FINISH:
 NOTES:

PART NUMBER

500053

REVISION

DESCRIPTION

Bumper Selection Guide



For additional assistance, contact us at info@ic13.us or 888-993-4213.

